

# LM237, LM337 3-TERMINAL ADJUSTABLE REGULATORS

SLVS047C – NOVEMBER 1981 – REVISED JULY 1999

- Output Voltage Range Adjustable From  $-1.2\text{ V}$  to  $-37\text{ V}$
- Output Current Capability of  $1.5\text{ A}$  Max
- Input Regulation Typically  $0.01\%$  Per Input-Voltage Change
- Output Regulation Typically  $0.3\%$
- Peak Output Current Constant Over Temperature Range of Regulator
- Ripple Rejection Typically  $77\text{ dB}$
- Direct Replacement for National Semiconductor LM237 and LM337

## description

The LM237 and LM337 are adjustable 3-terminal negative-voltage regulators capable of supplying in excess of  $-1.5\text{ A}$  over an output voltage range of  $-1.2\text{ V}$  to  $-37\text{ V}$ . They are exceptionally easy to use, requiring only two external resistors to set the output voltage and one output capacitor for frequency compensation. The current design has been optimized for excellent regulation and low thermal transients. In addition, the LM237 and LM337 feature internal current limiting, thermal shutdown, and safe-area compensation, making them virtually immune to failure by overloads.

The LM237 and LM337 serve a wide variety of applications, including local on-card regulation, programmable output-voltage regulation, and precision current regulation.

The LM237 is characterized for operation over the virtual junction temperature range of  $-25^{\circ}\text{C}$  to  $150^{\circ}\text{C}$ . The LM337 is characterized for operation over the virtual junction temperature range of  $0^{\circ}\text{C}$  to  $125^{\circ}\text{C}$ .

**KC PACKAGE  
(TOP VIEW)**

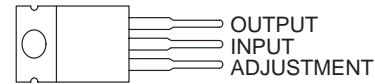

The INPUT terminal is in electrical contact with the mounting base.

**TO-220AB**

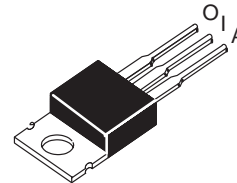

**KTE PACKAGE  
(TOP VIEW)**

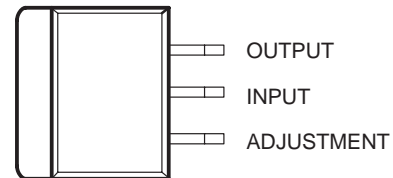

The INPUT terminal is in electrical contact with the mounting base.

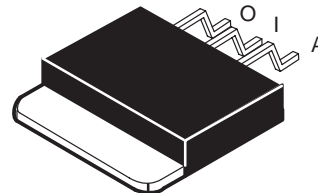

### AVAILABLE OPTIONS

$T_J$	PACKAGED DEVICES		CHIP FORM (Y)
	HEAT-SINK MOUNTED (KC)	PLASTIC FLANGE MOUNTED (KTE)	
$-25^{\circ}\text{C}$ to $150^{\circ}\text{C}$	LM237KC	LM237KTE	—
$0^{\circ}\text{C}$ to $125^{\circ}\text{C}$	LM337KC	LM337KTE	LM337Y

The KTE package is only available taped and reeled. Add the R suffix to the device type (e.g., LM237KTER). Chip forms are tested at  $25^{\circ}\text{C}$ .



Please be aware that an important notice concerning availability, standard warranty, and use in critical applications of Texas Instruments semiconductor products and disclaimers thereto appears at the end of this data sheet.

PRODUCTION DATA information is current as of publication date. Products conform to specifications per the terms of Texas Instruments standard warranty. Production processing does not necessarily include testing of all parameters.

**TEXAS  
INSTRUMENTS**

POST OFFICE BOX 655303 • DALLAS, TEXAS 75265

Copyright © 1999, Texas Instruments Incorporated



# LM237, LM337

## 3-TERMINAL ADJUSTABLE REGULATORS

SLVS047C – NOVEMBER 1981 – REVISED JULY 1999

### electrical characteristics over recommended ranges of operating virtual junction temperature (unless otherwise noted)

PARAMETER	TEST CONDITIONS†		LM237			LM337			UNIT		
			MIN	TYP	MAX	MIN	TYP	MAX			
Input regulation‡	$V_I - V_O = -3\text{ V to } -40\text{ V}$	$T_J = 25^\circ\text{C}$		0.01	0.02		0.01	0.04	%/V		
		$T_J = \text{MIN to MAX}$		0.02	0.05		0.02	0.07			
Ripple rejection	$V_O = -10\text{ V},$	$f = 120\text{ Hz}$		60			60	dB			
	$V_O = -10\text{ V},$	$f = 120\text{ Hz},$	$C_{\text{ADJ}} = 10\text{ }\mu\text{F}$	66	77		66		77		
Output regulation	$I_O = 10\text{ mA to } 1.5\text{ A},$	$T_J = 25^\circ\text{C}$	$ V_O  \leq 5\text{ V}$		25			50	mV		
			$ V_O  \geq 5\text{ V}$		0.3%	0.5%		0.3%	1%		
	$I_O = 10\text{ mA to } 1.5\text{ A}$	$ V_O  \leq 5\text{ V}$			50			70	mV		
		$ V_O  \geq 5\text{ V}$			1%			1.5%			
Output-voltage change with temperature	$T_J = \text{MIN to MAX}$			0.6%			0.6%				
Output-voltage long-term drift	After 1000 h at $T_J = \text{MAX}$ and $V_I - V_O = -40\text{ V}$			0.3%	1%		0.3%	1%			
Output noise voltage	$f = 10\text{ Hz to } 10\text{ kHz},$	$T_J = 25^\circ\text{C}$		0.003%			0.003%				
Minimum output current to maintain regulation	$ V_I - V_O  \leq 40\text{ V}$			2.5	5		2.5	10	mA		
	$ V_I - V_O  \leq 10\text{ V}$			1.2	3		1.5	6			
Peak output current	$ V_I - V_O  \leq 15\text{ V}$			1.5	2.2		1.5	2.2	A		
	$ V_I - V_O  \leq 40\text{ V},$		$T_J = 25^\circ\text{C}$	0.24	0.4		0.15	0.4			
Adjustment-terminal current				65	100		65	100	$\mu\text{A}$		
Change in adjustment-terminal current	$V_I - V_O = -2.5\text{ V to } -40\text{ V},$		$T_J = 25^\circ\text{C},$		2	5		2	5	$\mu\text{A}$	
Reference voltage (output to ADJ)	$V_I - V_O = -3\text{ V to } -40\text{ V},$	$T_J = 25^\circ\text{C}$		-1.225	-1.25	-1.275		-1.213	-1.25	-1.287	V
		$T_J = \text{MIN to MAX}$		-1.2	-1.25	-1.3		-1.2	-1.25	-1.3	
Thermal regulation	Initial $T_J = 25^\circ\text{C},$			0.002	0.02		0.003	0.04	%/W		

† Unless otherwise noted, these specifications apply for the following test conditions  $|V_I - V_O| = 5\text{ V}$  and  $I_O = 0.5\text{ A}$ . For conditions shown as MIN or MAX, use the appropriate value specified under recommended operating conditions. All characteristics are measured with a  $0.1\text{-}\mu\text{F}$  capacitor across the input and a  $1\text{-}\mu\text{F}$  capacitor across the output. Pulse-testing techniques are used to maintain the junction temperature as close to the ambient temperature as possible. Thermal effects must be taken into account separately.

‡ Input regulation is expressed here as the percentage change in output voltage per 1-V change at the input.

# LM237, LM337

## 3-TERMINAL ADJUSTABLE REGULATORS

SLVS047C – NOVEMBER 1981 – REVISED JULY 1999

### electrical characteristics, $T_J = 25^\circ\text{C}$

PARAMETER	TEST CONDITIONS†	LM237, LM337			UNIT
		MIN	TYP	MAX	
Input regulation‡	$V_I - V_O = -3\text{ V to } -40\text{ V}$		0.01	0.04	%/V
Ripple rejection	$V_O = -10\text{ V}, \quad f = 120\text{ Hz}$		60		dB
	$V_O = -10\text{ V}, \quad C_{ADJ} = 10\ \mu\text{F}, \quad f = 120\text{ Hz}$		66	77	
Output regulation	$I_O = 10\text{ mA to } 1.5\text{ A}$	$ V_O  \leq 5\text{ V}$		50	mV
		$ V_O  \geq 5\text{ V}$	0.3%	1%	
Output noise voltage	$f = 10\text{ Hz to } 10\text{ kHz}$		0.003%		
Minimum output current to maintain regulation	$ V_I - V_O  \leq 40\text{ V}$		2.5	10	mA
	$ V_I - V_O  \leq 10\text{ V}$		1.5	6	
Peak output current	$ V_I - V_O  \leq 15\text{ V}$		1.5	2.2	A
	$ V_I - V_O  \leq 40\text{ V}$		0.15	0.4	
Adjustment-terminal current			65	100	$\mu\text{A}$
Change in adjustment-terminal current	$V_I - V_O = -2.5\text{ V to } -40\text{ V}, \quad I_O = 10\text{ mA to MAX}$		2	5	$\mu\text{A}$
Reference voltage (output to ADJ)	$V_I - V_O = -3\text{ V to } -40\text{ V}, \quad I_O = 10\text{ mA to } 1.5\text{ A}, \quad P \leq \text{rated dissipation}$	-1.213	-1.25	-1.287	V

† Unless otherwise noted, these specifications apply for the following test conditions  $|V_I - V_O| = 5\text{ V}$  and  $I_O = 0.5\text{ A}$ . All characteristics are measured with a  $0.1\text{-}\mu\text{F}$  capacitor across the input and a  $1\text{-}\mu\text{F}$  capacitor across the output. Pulse-testing techniques are used to maintain the junction temperature as close to the ambient temperature as possible. Thermal effects must be taken into account separately.

‡ Input regulation is expressed here as the percentage change in output voltage per 1-V change at the input.



APPLICATION INFORMATION

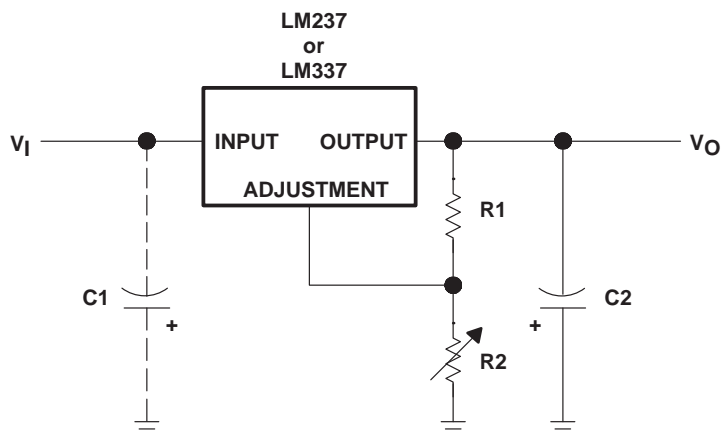

R1 is typically 120 Ω.

$$R2 = R1 \left( \frac{-V_O}{-1.25} - 1 \right) \text{ where } V_O \text{ is the output in volts.}$$

C1 is a 1-μF solid tantalum capacitor required only if the regulator is more than 10 cm (4 in) from the power-supply filter capacitor. C2 is a 1-μF solid tantalum or 10-μF aluminum electrolytic capacitor required for stability.

Figure 1. Adjustable Negative-Voltage Regulator

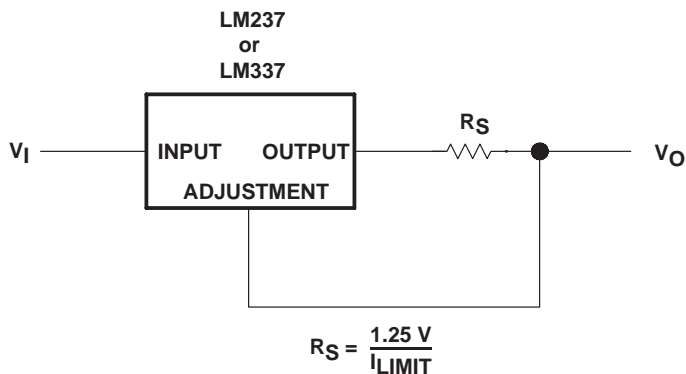

Figure 2. Current-Limiting Circuit

## IMPORTANT NOTICE

Texas Instruments and its subsidiaries (TI) reserve the right to make changes to their products or to discontinue any product or service without notice, and advise customers to obtain the latest version of relevant information to verify, before placing orders, that information being relied on is current and complete. All products are sold subject to the terms and conditions of sale supplied at the time of order acknowledgement, including those pertaining to warranty, patent infringement, and limitation of liability.

TI warrants performance of its semiconductor products to the specifications applicable at the time of sale in accordance with TI's standard warranty. Testing and other quality control techniques are utilized to the extent TI deems necessary to support this warranty. Specific testing of all parameters of each device is not necessarily performed, except those mandated by government requirements.

CERTAIN APPLICATIONS USING SEMICONDUCTOR PRODUCTS MAY INVOLVE POTENTIAL RISKS OF DEATH, PERSONAL INJURY, OR SEVERE PROPERTY OR ENVIRONMENTAL DAMAGE ("CRITICAL APPLICATIONS"). TI SEMICONDUCTOR PRODUCTS ARE NOT DESIGNED, AUTHORIZED, OR WARRANTED TO BE SUITABLE FOR USE IN LIFE-SUPPORT DEVICES OR SYSTEMS OR OTHER CRITICAL APPLICATIONS. INCLUSION OF TI PRODUCTS IN SUCH APPLICATIONS IS UNDERSTOOD TO BE FULLY AT THE CUSTOMER'S RISK.

In order to minimize risks associated with the customer's applications, adequate design and operating safeguards must be provided by the customer to minimize inherent or procedural hazards.

TI assumes no liability for applications assistance or customer product design. TI does not warrant or represent that any license, either express or implied, is granted under any patent right, copyright, mask work right, or other intellectual property right of TI covering or relating to any combination, machine, or process in which such semiconductor products or services might be or are used. TI's publication of information regarding any third party's products or services does not constitute TI's approval, warranty or endorsement thereof.